

Primer on Medical Decision Analysis:

Part 5-Working with Markov Processes

DAVID NAIMARK, MD, MURRAY D. KRAHN, MD, MSc,
GARY NAGLIE, MD, MSc, DONALD A. REDELMEIER, MD, MS(HSR),
ALLAN S. DETSKY, MD, PhD

Clinical decisions often have long-term implications. Analysts encounter difficulties when employing conventional decision-analytic methods to model these scenarios. This occurs because probability and utility variables often change with time and conventional decision trees do not easily capture this dynamic quality. A Markov analysis performed with current computer software programs provides a flexible and convenient means of modeling long-term scenarios. However, novices should be aware of several potential pitfalls when attempting to use these programs. When deciding how to model a given clinical problem, the analyst must weigh the simplicity and clarity of a conventional tree against the fidelity of a Markov analysis. In direct comparisons, both approaches gave the same qualitative answers. *Key words:* decision analysis; expected value; utility; sensitivity analysis; decision trees; probability. (Med Decis Making 1997; 17:152-159)

Markov Processes-General Principles

Part 2 of this series discusses the construction of a decision tree for the management of possible giant cell arteritis (GCA) in order to illustrate the principles of medical decision analysis. The model considers the short-term consequences of three treatment strategies: treat all patients with steroid, treat no patient, and perform a temporal artery biopsy and treat only those with positive results. Despite the comprehensive structure of the decision tree, there is a long-term management issue that is not captured by the model. Since the acute arteritis may relapse, maintenance steroid prophylaxis for up to two years has been recommended. However, long-term use of corticosteroids may lead to a number of complications. The treatment decision is vexing because the sequelae of both the disease and the prophylactic therapy may be permanent. A more re-

alistic model would consider the short-term consequences of the treatment decision as well as the long-term tradeoff between the risk of relapse and the chance of a serious complication from steroid treatment. Indeed, many clinical decisions have long-term implications for patients, and a general decision-analytic strategy is required to handle these problems.

With respect to the GCA model, the most straightforward solution is to add branches representing a relapse and its consequences to the existing tree and extend the horizon of the analysis. Unfortunately, this approach creates three problems for the analyst. First, probability values may change with time, which complicates their calculation. For example, the probability of a GCA relapse might decrease with time. In this case, the analyst could base the estimate on the assumption that all relapses occur at the midpoint of the time horizon-which is unrealistic-or could employ a time-averaged probability of relapse-which may be difficult to derive if the probability changes in a nonlinear fashion. Second, the extended horizon creates problems when computing utility values. For example, a conventional decision tree would have one term for the disutility of a GCA complication. However, most people are less concerned about an adverse event that might occur in the future compared with one that might occur in the present-a process known as "discounting." In general, the values of utilities and disutilities should change with time. Again, the analyst would be forced to employ either "midpoint" or time-averaging methods to calculate these varia-

Received November 27, 1995, from the University of Toronto Programme in Clinical Epidemiology and Health Care Research (The Toronto Hospital and The Sunnybrook Health Science Centre Units) and the Departments of Health Administration, Medicine, and Clinical Biochemistry, Toronto, Ontario, Canada. Revision accepted for publication December 12, 1996. Drs. Detsky and Redelmeier are partially supported by Career Awards from the National Health Research and Development Programme and the Ontario Ministry of Health, respectively. Drs. Naglie and Krahn are partially supported by Arthur Bond Fellowships from the Physicians' Services Incorporated Foundation.

Address correspondence and reprint requests to Dr. Detsky: EN G-246, General Division, The Toronto Hospital, 200 Elizabeth Street, Toronto, ON M5G 2C4, Canada. e-mail: (detsky@utstat.toronto.edu).

bles. Third, it is often desirable to consider events that may occur over a lifetime. A conventional decision tree requires the analyst to explicitly state the length of the time horizon in order to compute probabilities and utilities, yet life-spans vary. Calculating appropriate probabilities and utilities for use in a decision tree based on an indeterminate horizon is not straightforward.

A Markov process is a modeling technique, derived from matrix algebra, that solves many of the difficulties encountered when trying to fit the "square peg" of a long-term clinical problem into the "round hole" of a conventional decision tree. At first glance, a Markov process may appear to be a radical departure from the standard decision tree; however, the two modeling approaches do have a conceptual similarity. A conventional tree describes the ways in which a cohort of patients in one health state might end up in other states over a fixed time period. For example, patients in a state defined by the presence of GCA may suffer a complication of the disease (such as vasculitis of the ophthalmic artery) and enter a new health state defined by the chronic sequelae of the complication (blindness). Markov processes also characterize the transitions of a cohort of patients among a number of health states. However, instead of considering health-state transitions over a fixed time period, a Markov process is concerned with transitions during a series of short intervals or cycles.

When constructing a Markov process, the analyst first delineates a set of mutually exclusive health states that patients might reasonably experience (e.g., WELL, SICK, and DEAD-figure). He or she next determines the ways in which patients in these states might behave during a brief time interval or cycle. For example, patients in the WELL state may stay well, become sick, or die during any given cycle. Patients in the SICK state may remain ill or die, while patients in the DEAD state must remain dead. Each of these contingencies is called a "state transition" and has an associated "transition probability." The duration of a cycle is arbitrary and depends on the nature of the clinical problem being modeled. One year may be an appropriate length for conditions with low frequencies of clinical events, while shorter cycle lengths may be more suitable for acute illnesses.

A bubble diagram (figure 1) is an intuitive way to visualize a Markov process. The health states are represented by rows of bubbles, with one row for each cycle. The transitions between states are denoted as arrows with the transition probabilities written beside them. The distribution of patients among the health states at the beginning of the process is determined by the analyst. For example, the analyst may wish to consider a cohort of patients

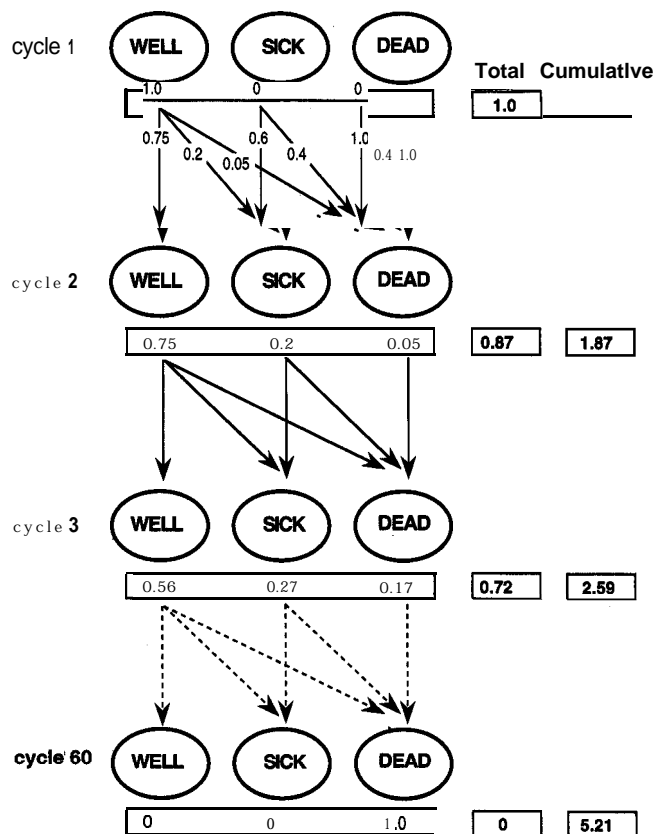

FIGURE 1. Bubble-diagram representation of a three-state Markov process. In this process, patients may exist in one of three states: WELL, SICK, and DEAD. Each row represents one cycle of the Markov process. Within each row, the states are represented by ovals. Transitions between states are represented as arrows linking the ovals. The transition probabilities are written beside the arrows for the first cycle (these probabilities remain constant for this particular process). The fraction of the cohort in each state at the beginning of each cycle is shown in the box below the row. The incremental utilities for the WELL, SICK, and DEAD states are 1.0, 0.6, and 0.0, respectively (not shown). The total incremental and cumulative utility for each cycle are shown in boxes to the right of the row. Total = total incremental utility, Cumulative = cumulative utility (see text for definitions of total incremental and cumulative utility).

who are all initially in the WELL state (fig. 1). In subsequent cycles, the distribution of patients among the states depends on their distribution in the previous cycle and the transition probabilities between the states. The rows of the process are analogous to the frames of a movie—each cycle or frame is a snapshot of the cohort during a brief period of time. Moving down row by row through the process is similar to running the film through a projector: the analyst is able to observe the behavior of the cohort forward through time.

After constructing the Markov process and considering the transition probabilities, the analyst assigns to each state an incremental utility that indicates the relative value of occupying it for one cycle. For example, incremental utilities of 1.0, 0.6, and 0.0

could be assigned to the **WELL**, **SICK**, and **DEAD** states, respectively (i.e., a cycle spent in the **SICK** is equivalent to **0.6** months spent in the **WELL** state). That is, the members of the cohort who spend one cycle in the **SICK** state each contribute 0.6 quality-adjusted life months or QALMs to the total for the cohort. Multiplying the incremental utility for each state by the fraction of the cohort occupying that state and then summing across all of the states yields the **total** incremental utility generated by the cohort for a given cycle. Thus, during the second cycle (fig. 1), the total incremental utility is $[1.0 \times 0.751 + 10.6 \times 0.21 + 0.0 \times 0.051 = 0.87$ QALMs. Notice that the total incremental utility would have units of quality-adjusted life years (QALYs) if the cycle length had been one year.

The **cumulative** utility is running tab of the total incremental utility generated during each cycle. For example, after three cycles the cumulative utility is $1.0 + 0.87 + 0.72 = 2.59$ QALMs (fig. 1). Although the cumulative utility increases as the number of cycles increases, it tends toward a limiting value. This occurs because the **DEAD** state is an absorbing state (i.e., patients may enter but may not leave) and its incremental utility is 0. As the cycle number increases, more and more of the cohort die, which leaves progressively fewer individuals to generate incremental utility. Usually the analyst terminates the process when the total incremental utility generated during each subsequent cycle would be less than a minimum value (e.g., 0.0001 QALMs). The cumulative utility at that point is considered to be the “output” of the Markov process, just as the expected or average utility is the output from a conventional decision tree. For the three-state process, the total incremental utility generated by each cycle approaches zero after 60 cycles and the cumulative utility at that point is 5.2 quality-adjusted life months (i.e., the output of this process is 5.2 QALMs—fig. 1). Terminating the process when the total incremental utility drops below a threshold solves one of the shortcomings of a conventional decision tree: the analyst is not required to specify the time horizon of the analysis a priori. Indeed, different cohorts within the same decision model will experience different numbers of cycles depending on the per-cycle probability of being absorbed.

Markov Analysis Applied to the GCA Problem

In the following sections, aspects of the creation of a Markov analysis are illustrated for the GCA problem. We use terminology and modeling conventions employed by **SMLTREE** (Hollenberg JP. Version 2.9. Roslyn, NY) and **DECISION MAKER** (Pratt Medical

Group, Boston, MA), the two most commonly used decision-analytic computer programs. We define a “Markov analysis” as a decision model that contains Markov processes as elements of a larger structure. For example, figure 2 shows Markov processes incorporated into the GCA decision tree. Within the main tree, patients may either truly have GCA or have another condition. For those who undergo temporal artery biopsy, the result may be either positive or negative depending on the presence or ab-

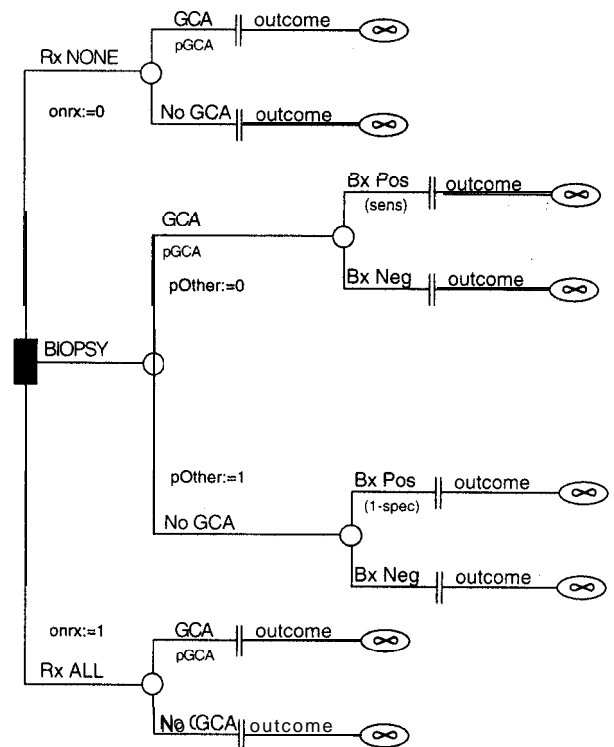
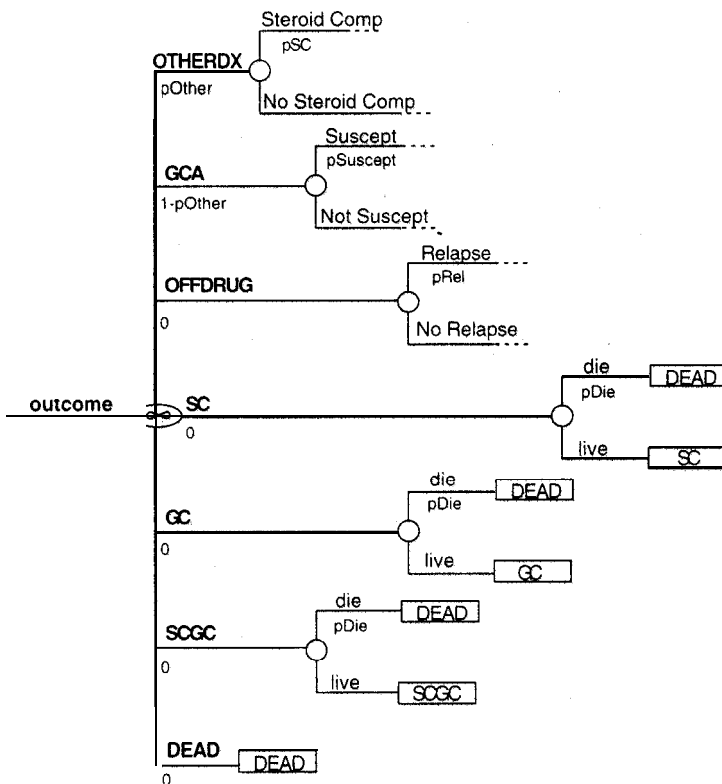

FIGURE 2. Main tree with Markov subtrees. The main tree indicates three management options for patients with possible giant cell arteritis (GCA): **Rx NONE** (give steroid to no patients), **Rx ALL** (give steroid to every patient), and **BIOPSY** (perform a temporal artery biopsy and treat those with a positive result). The subsequent structure indicates the true underlying condition of patients and the result of a temporal artery biopsy (if patients are tested). The result of this test is a function of the prevalence of GCA and its sensitivity and specificity. A common Markov subtree, “outcome,” is attached to each branch of the main tree. Binding expressions located on the main tree indicate whether or not patients really have GCA and whether or not they receive steroid. Examples of these binding expressions are shaded. “pOther” is an indicator that is bound to the value of 1 for patients who have an alternate diagnosis and 0 if they really have GCA. “onrx” is another indicator, which is bound to the value 1 on branches where patients are treated and 0 elsewhere. These two indicator variables are used within “outcome” so that the same subtree structure can be attached to different places on the main tree (see text). Notice that, for clarity, several binding expressions are omitted from the diagram. No GCA = an alternate diagnosis; Bx Pos and Bx neg = positive and negative biopsy, respectively; pGCA = probability of GCA; sens = sensitivity of temporal artery biopsy; spec = specificity of biopsy.

FIGURE 3. Markov subtree "outcome." A Markov subtree consists of a Markov node (indicated by the oval with the infinity symbol) and its branches, which represent the states of the Markov process. In the process represented by the "outcome" subtree, there are seven states: OTHERDX, GCA, OFFDRUG, SC, GC, SCGC, and DEAD (see text for descriptions of these states). The probability value beneath each branch indicates the fraction of the cohort initially in that state. Special binding expressions for the variables m.UINIT, m.UINCR, and m.UTAIL, are located on each branch but are not illustrated. Each branch is connected to a cycle tree that indicates the transitions between states during a given cycle (see figs. 4,5, and 6). OTHERDX, GCA, OFFDRUG, SC, GC, SCGC, and DEAD = states of the Markov process; Steroid Comp = steroid complication; pSC = probability of a steroid complication per cycle; Suscept = susceptibility to a GCA complication; pSuscept = probability of being susceptible to a GCA complication; Relapse = relapse of acute GCA; pRel = probability of acute GCA relapse per cycle; pDie = probability of death. Other abbreviations as in figure 2.



sence of GCA and the sensitivity and specificity of the test. Subsequent events are modeled by Markov processes that are represented by a special structure: the Markov subtree "outcome."

Folding back the model occurs in two steps. First, each Markov subtree is evaluated in turn-i.e., the output from each is computed. Binding expressions upstream from "outcome" allow the same Markov subtree to function differently when attached to different branches of the main tree. In other words, the numbers of QALMs generated by "outcome" will be different on the various branches of the main tree. Second, the main tree is folded back in the usual fashion except that the value of each of its branches is the number of QALMS generated by the attached Markov subtree rather than a conventional utility. Folding back to the decision node yields the quality-adjusted life expectancy (i.e., the average or expected number of QALMs) associated with each strategy. The optimum strategy is the one that yields the greatest quality-adjusted life expectancy. Notice that the cycle length for the analysis is arbitrarily set at one month. If a cycle length of one year had been chosen, the output of the model would be in terms of quality-adjusted life years (QALYs).

The structure of "outcome" consists of a Markov node and its branches. Each branch represents one of the health states associated with the process (fig. 3): OTHERDX (patients with alternate diagnoses); GCA (patients who truly have GCA); OFFDRUG (patients

who began the process in GCA, had a steroid complication at some previous cycle, and are now off the medication); SC (patients initially in OTHERDX who had a steroid complication); GC (patients initially in GCA who had a GCA complication); SCGC (patients with GCA who had both a GCA complication and a steroid complication); and DEAD (patients who died during a previous cycle). The set of probability expressions written under the branches of the Markov node has a special meaning: it represents the initial distribution of the cohort entering the process. The probabilities under the OFFDRUG, SC, GC, SCGC, and DEAD states are zeros, which indicates that none of the cohort occupies these states initially. The value of "pOther" is bound upstream from "outcome" (fig. 2). If "outcome" is attached to a branch representing patients who truly have GCA, "pOther" has the value zero and all the patients begin the process in the GCA state. The opposite happens for "outcome" subtrees attached to branches representing the absence of the disease. This allows the same subtree structure to function appropriately when attached to different places in the main tree and spares the analyst from having to construct a unique subtree for each branch of the main tree.

In SMLTREE, each branch of the Markov node has a set of special binding variables-m.UINIT, m.UINCR, and m.UTAIL. The middle variable is the incremental utility of the particular state, the value of the first variable should be set to one-half of the incremental

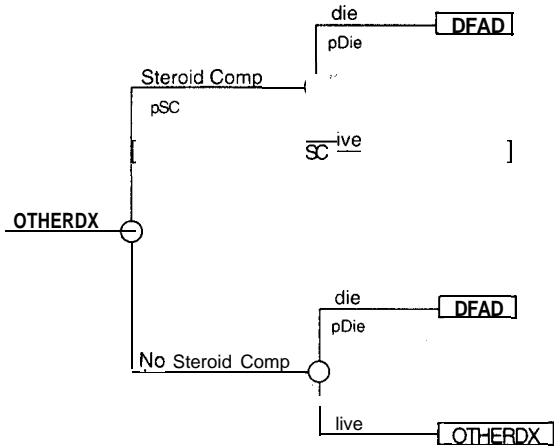

FIGURE 4. OTHERDX cycle tree. The possible transitions between OTHERDX and other states are shown. The probability of death is modified in the upper branch with a regular binding expression (not shown). Other abbreviations as in previous figures.

utility of the state (this is a correction factor that increases the accuracy of the process), and, in almost all cases, the last variable should be set to zero.² For example, if the incremental utility of the SCGC state is 0.7, then the value of $iuSCGC$ would be set globally to 0.7 and the following set of binding expressions would be placed on the SCGC branch of the Markov node: $m.UINIT: =0.5*iuSCGC$; $m.UINCR: =iuSCGC$; $m.UTAIL: =0.0$.

Each branch of the Markov node is connected to a "cycle tree" that has a structure similar to that of

a conventional subtree except that the terminal branches do not have associated utility values. Instead, they indicate the states that patients will occupy **during** the next cycle. The chance nodes collectively indicate possible transitions during the course of a cycle and their probabilities. The Markov subtree is equivalent to visualizing the process as a bubble diagram but has the advantages of being more compact and providing more detail about how the transitions occur between states. Patients who do not have arteritis begin the process in the OTHERDX state (fig. 41). If they do not experience a steroid side effect and do not die of unrelated causes during the course of a cycle, they remain in the OTHERDX state; if they suffer a steroid side effect and live, they transfer to the SC state; and if they die, they are absorbed into the DEAD state. The probability of suffering a steroid complication, pSC , is the **per-cycle** probability of that event and is set to zero on branches in which patients are not treated with corticosteroid (notice that these probability expressions are different from those employed in Part 2 of this series¹ in order to emphasize that they represent the chances of events per cycle).

Individuals who do have arteritis begin the process in the GCA state (fig. 5). They are susceptible to a GCA complication during the first cycle, when the arteritis is acute, and in subsequent cycles if they do not receive steroid treatment (see below). Depending on the sequence of events that occur during the cycle, patients may remain in the GCA state or make

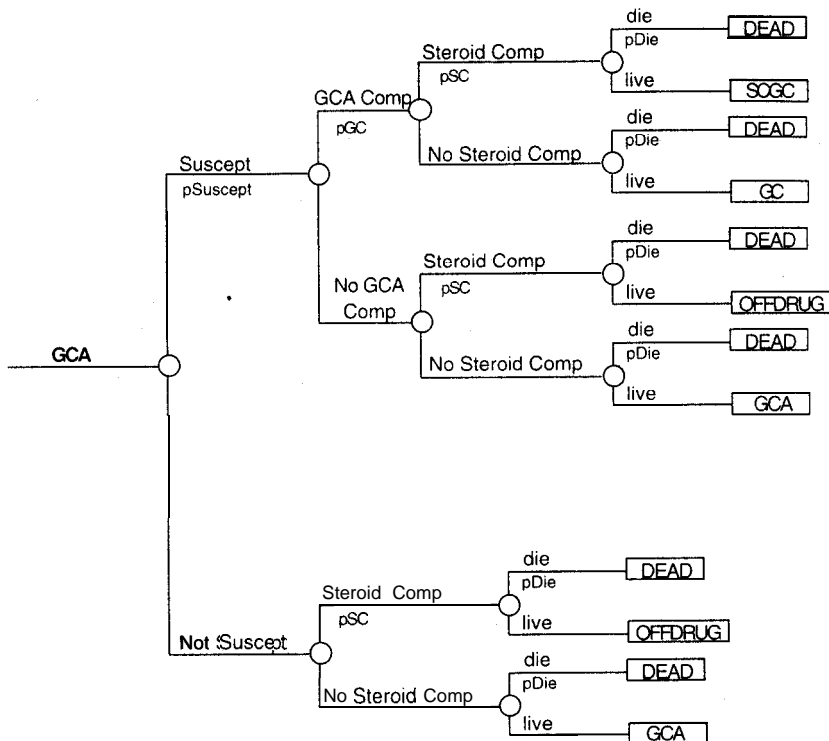

FIGURE 5. GCA cycle tree. The possible transitions between GCA and other states are shown. Patients are susceptible to a GCA complication during the first cycle and subsequent cycles if steroid prophylaxis is not given. This is achieved through the use of passbindings (see text). The probability of death is modified on the appropriate branches with regular binding expressions (not shown). The probability of a steroid complication is modified by passbindings (see text). GCA Comp = GCA complication; pGC = probability of a GCA complication. Other abbreviations as in previous figures.

transitions into a number of others. If they suffer a steroid complication but not a GCA complication and survive, the treatment is discontinued and they transfer into the OFFDRUG state (fig. 6). In this state, they face the possibility that acute arteritis may relapse and that a GCA complication may occur. The SC, GC, and SCGC states represent the long-term sequelae of having suffered a steroid complication, a GCA complication, or both (fig. 3). They each have a relatively high per-cycle probability of dying and a relatively low incremental utility. The DEAD branch represents the absorbing state with m.UINIT, m.UINCR, and m.UTAIL all set to zero. Notice that the choice to model the problem this way is arbitrary and made for the sake of illustration.

The Markov subtree representation provides a convenient method for allowing probability and utility values to change with time. In SMLTREE, when a Markov subtree is being evaluated, the number of elapsed cycles is recorded as a special variable m.CYCLE. Special binding expressions, "passbindings," allow probability and utility values to be functions of m.CYCLE. SMLTREE requires the use of passbindings because of the way it evaluates regular binding expressions. For example, let "pEvent" denote the probability of an event in one of the cycle trees of a Markov node. If a regular expression "pEvent:=b*m.CYCLE" is placed on a branch upstream from a Markov subtree, "pEvent" is computed with the current values of b and m.CYCLE that exist on the branch where the binding expression is located. The **value** of the calculation is passed downstream. Since m.CYCLE is zero outside the Markov subtree, "pEvent" would have the unchanging value of zero within the Markov subtree. In contrast, the expression "pEvent: =passbind(b*m.CYCLE)" instructs the program to delay the evaluation of the expression until "pEvent" is encountered within the Markov subtree. At that point, the value of m.CYCLE is changing so that "pEvent" changes from cycle to cycle as well. Regular bindings pass the **value** of an expression downstream, while passbindings pass the actual **expression** downstream.

Examples of the Use of Passbindings

Passbinding expressions do not need to be any more complicated than the one shown above. However, the use of more complex passbindings provides the intermediate to advanced analyst with a plethora of modeling options. For example, if the probability of a steroid complication falls as a declining exponential function of time, the binding expression

$$"pSC:=passbind[pSCo*exp(-1*k*m.CYCLE)]"$$

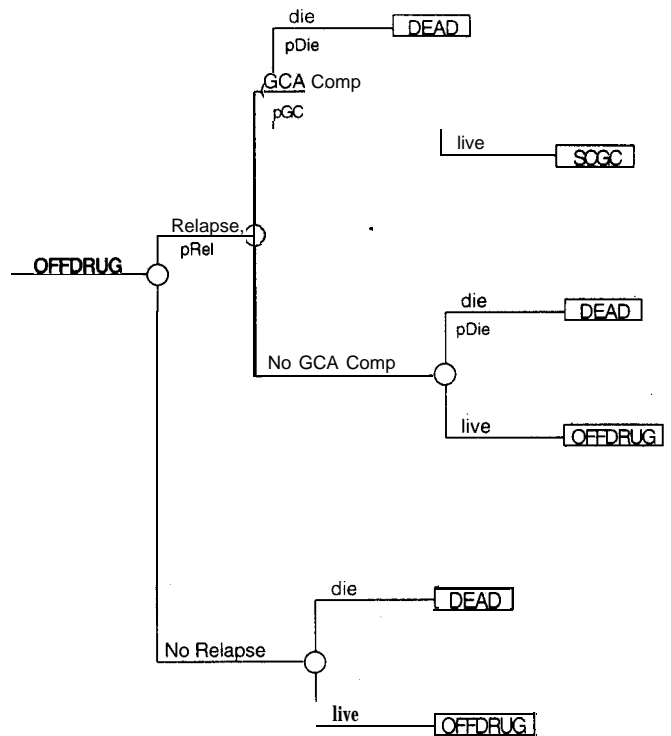

FIGURE 6. OFFDRUG cycle tree. The possible transitions between OFFDRUG and other states are shown. Patients who have a steroid complication but no GCA complication discontinue the steroid and face the possibility of relapse of acute GCA and its complications. Abbreviations as in previous figures.

could be placed upstream from the Markov subtree (where "pSC" is the probability of a complication at a given value of m.CYCLE, "pSCo" is the probability at the beginning of the process, and k is the slope constant of the exponential function). Since a patient can experience a steroid complication only if he or she is taking the drug, the passbinding expression could be rewritten as

$$"pSC:=passbind[onrx*pSCo*exp(-1*k*m.CYCLE)]"$$

The new term is the indicator variable, "onrx," which is set to 1.0 on branches of the main tree representing patients who receive steroid and set to 0.0 elsewhere. Thus, "pSC" has a non-zero value only in "outcome" subtrees attached to branches of the main tree where patients are treated (fig. 2). Passbindings can be even more sophisticated through the use of logical expressions. For example, if steroid therapy is limited to two years, then the probability of a steroid complication should drop to zero after 24 months. The passbinding expression above could be rewritten as

$$"pSC: =passbind[(m.CYCLE <= 24) * onrx * pSCo * exp(-1 * k * m.CYCLE)]"$$

The new term is $(m.CYCLE \leq 24)$, which is a logical expression. It has the value 1.0 when $m.CYCLE$ is less than or equal to 24 (the expression is true) and the value of 0.0 when $m.CYCLE$ is greater than 24 (the expression is false). Compound logic expressions are also possible. In the GCA cycle tree (fig. 5), only patients during the first cycle or those who never receive steroid are susceptible to a GCA complication. Placing the expression

`"pSuscept:=passbind[(m.CYCLE=1)|(onrx=0)]"`

on branches upstream from the Markov subtree achieves this feature. In *SMLTREE*, the "!" symbol is the logical "or" and the "&" symbol is the logical "and." Thus, "pSuscept" has the value 1.0 if either the process is in the first cycle, the patients are not on treatment, or both, but has the value 0 if both statements are false. Finally, some probability values change in ways that are not easily written as mathematical expressions (e.g., the age- and sex-specific mortality rates in the general population). Sonnenberg and Beck⁷ provide a detailed explanation of how to use the "tables" facility of *SMLTREE* and *DECISION MAKER* within passbinding expressions.

Passbindings may also be used to alter incremental utility values as functions of $m.CYCLE$. For example, the pair of binding expressions

`"years:=passbind[int(m.CYCLE/12)]"`

and

`"iuOTHERDX:=passbind[iuOTHERDXO/(discrete^years)]"`

could be placed upstream of the "outcome" subtree in order to discount the value of being in the *OTHERDX* state. The term $\text{int}(m.CYCLE/12)$ gives the integer number of years that have elapsed when the cycle length is one month; $(\text{discrete}^{\text{years}})$ gives the discount rate raised to the power of the number of elapsed years; and iuOTHERDXO is the incremental utility during the first year. For example, if the base incremental utility during the first year is 0.90 and the discount rate is 5%, then after 31 months, "years" would be equal to 2 and "iuOTHERDX" would be $0.9/(1.05^2) = 0.82$. Thus, the combination of the $m.CYCLE$ variable and passbindings provides a convenient and flexible solution to the problem of probability and utility values that change with time.

Practical Considerations Regarding Markov Subtrees: Bug-proofing

As the complexity of a tree or the resolution of the Markov process (i.e., the number of cycles) in-

creases, the importance of computational efficiency rises. For the GCA problem, the main-tree-plus-Markov-subtree structure was employed because an acute event (the temporal artery biopsy¹ was not modeled to be a long-term consideration. In general, however, if the Markov subtrees can be attached directly onto the decision node (avoiding the main tree altogether), the analysis will run more efficiently? Decision trees that have Markov elements may be especially difficult to debug. As for conventional trees, one-way sensitivity analysis is used as a debugging and analytic tool in decision models with Markov subtrees. However, since an ounce of prevention is worth a pound of cure, a few precautions will help to avoid bugs. The most obvious mistake is to set the termination criterion to be a total incremental utility less than 0.0001 per cycle and then omit an absorbing state. Without an absorbing state that contributes zero (or very little) incremental utility per cycle, the Markov process will never terminate! Likewise, regular binding expressions of the type $a:=a+1$ are perfectly legitimate outside the Markov subtree, but an expression $a:=\text{passbind}(a+1)$ will result in an infinite loop. Fortunately, *SMLTREE* prevents the user from attempting to incorporate self-referential passbindings. The experienced Markov modeler is wary of the errors digital computers may commit when performing mathematical calculations: i.e., errors due to rounding, to overflow, and to the binary representation of real numbers and integers. A prudent approach is to constrain the results of an expression. If the probability of an event p is equal to $a * b$, then one should write the binding expression as $p:=\text{min}[1,(a*b)]$. The "min" function gives the minimum of the two values 1 and $a*b$, which constrains p to be less than or equal to 1. Likewise, $p:=\text{max}\{0,\text{min}[1,(a*b)]\}$ constrains p to lie between 0 and 1. The "max" function can also be used to prevent the process from attempting to take logarithms of negative numbers.

Some "probabilities" in a cycle tree are more properly described as rates—i.e., the chance of an event per unit time. For example, "pSC" is the chance of a steroid complication per cycle. If the analyst decides to change the cycle length, then rates within the cycle-tree must be recalculated. The most common way to adjust rates is to assume that they are an exponential function of time:

$$P(\emptyset)_t = \exp(-qt)$$

where $P(\emptyset)_t$ is the probability of not experiencing an event over time t , and q is the slope constant of an exponential function. An equivalent expression is

$$P(\emptyset)_t = [P(\emptyset)_1]^t$$

where $P(\emptyset)_1$ is the probability of not experiencing

the event per unit time (see appendix). For example, if the chance of experiencing a steroid complication is **40% or 0.4** over one year, then $P(\text{OE})_1$ is 0.6 and the probability of **no** steroid complication over one month is $P(\text{OE})^{1/12} = [0.6]^{1/12} = 0.958$. Thus, the probability that a steroid complication **does** occur over one month is roughly 4%.

Closing Comments

Like the clinical and health-policy scenarios for which decision analyses are designed, the choice between a simple tree and one with Markov elements involves a risk-benefit tradeoff. Simple trees that have extended, fixed time horizons offer the advantages of their simplicity: the tree structure is usually easier to explain to colleagues (i.e., the trees are more transparent) and their behavior during sensitivity analysis is usually easier to understand. As noted in Part 4 of this series, decision trees invariably have bugs, and it is often a much less onerous task to find bugs in simple trees. However, simple trees force the analyst to make less-than-realistic assumptions about the behaviors of probability and utility values over time. Markov processes solve some of the limitations of the simple trees, but they do so at the risk of adding a new dimension of opacity and quirky behavior during sensitivity analyses. Only one author has directly compared the performances of simple trees and Markov processes.³ The use of the more complex models did not appear to provide extra insight into the clinical problems: that is, there was no qualitative difference between the Markov and simple-tree approaches. However, only ten decision models were compared.

This marks the end of our five-part series. We also refer readers to our accompanying piece on oral presentation of decision analyses.⁴ We hope that we have given the reader many practical recommendations that will help him or her tackle the difficult task of actually performing a decision analysis. Through the years we have learned that students who are comfortable manipulating and interpreting algebraic expressions and have an aptitude for simple computer programming find this task relatively easy. Those who have difficulty with those tasks have plenty of trouble! We recommend beginning with a very simple decision tree for your first attempt.

The authors are grateful to those who have had very significant impacts on their learning in this area: Steve Pauker, Joe Lau, Dennis Plante, Jerry Kassirer, Frank Sonnenberg, Mark Eckman, John Wong, Brian Cohen, Hal Sox, Alan Garber, and Douglas Owens. They also acknowledge the manuscript reviewers, particularly Bruce Hillner, for their many useful suggestions. Finally, they acknowledge the most important influence on their teaching, namely the more than 150 students who have taken their course.

References

1. Detsky AS, Naglie G, Krahn MD, Redelmeier DA, Naimark D. Primer on medical decision analysis: Part Z-building a tree. *Med Decis Making*. 1997;17:126-35.
2. Sonnenberg FA, Beck JR. Markov models in medical decision making: a practical guide. *Med Decis Making*. 1993;13:322-38.
3. Moskowitz AJ, Dunn VH, Lau J, Pauker SG. Can "hypersimplified" decision trees to be used instead of Markov models? [abstr]. *Med Decis Making*. 1984;4:530.
4. Redelmeier DA, Detsky AS, Krahn MD, Naimark D, Naglie G. Guidelines for verbal presentations of medical decision analyses. *Med Decis Making*. 1997;17:228-30.

Glossary

Cycle: A brief time interval during which patients within a cohort may make a transition into another health state or remain in the current health state.

Cycle tree: A special subtree structure that, for a given health state, describes the possible events that might occur during a cycle, their probabilities, and the states occupied during the next cycle as a result of those events.

Incremental utility: The relative value of occupying a particular health state for one cycle.

Markov process: A modeling technique, derived from matrix algebra, that describes the transitions a cohort of patients make among a number of health states during a series of short intervals or cycles.

Markov subtree: A special subtree structure that represents Markov processes within a larger decision tree.

Passbindings: Special binding expressions within the SMLTREE program that allow probability and utility values to be functions of a special variable, "m.CYCLE." The latter variable counts the number of cycles that have elapsed since the beginning of the Markov process.

Transition probability: The chance that patients in a particular health state might transfer into another particular health state during the course of a cycle.

APPENDIX

Let $p(t)$ be the probability of avoiding an adverse event per unit time, let $p(1)$, the probability of avoiding an adverse event at time t , be a declining exponential function of time with slope k

Thus, if $p(t) = \exp[-kt]$
 then $p(1) = \exp[-k]$
 and $k = -\ln[p(1)]$
 and $p(t) = \exp[-\{-\ln[p(1)]\}t]$
 since $\exp(ab) = [\exp(a)]^b$
 let $a = -\{-\ln[p(1)]\} = \ln p(1)$ and $b = t$
 then $p(t) = \{\exp[\ln p(1)]\}^t$
 and $p(t) = p(1)^t$